



TRUCK MIXER MAINTENANCE & OPERATION HANDBOOK



Maintenance and Operation Handbook	4
Storage of the Guide.....	4
Safety at the Workplace	4
Personal Safety Equipment.....	4
Special Precautions.....	5
Purpose of Use and Identification Label	6
Features	7
Technical Data.....	7
Dimensions and Weights	7
Description of the Truck Mixer	8
Operation of the Truck Mixer	9
Start-Up.....	9
Start-Up in Winter.....	9
Filling the Water Tank.....	10
Filling the Drum.....	10
Loading Operation	11
Loading Location.....	11
Post-Loading Inspection Before Shipment.....	11
Preparations for Shipment and Unloading.....	12
Mixing.....	12
Cleaning Guide of the Truck Mixer	12
Maintenance of the Truck Mixer	13
Corrosion and Replacement of Metal Parts.....	16
Maintenance of the Hydraulic System.....	16
Replacement of the Oil of the Hydraulic System.....	16
Replacement of the Oil Filter Cartridge.....	17
Maintenance of the Gearbox.....	18
Replacement of the Gearbox Oil.....	18
Maintenance of the Water Pump.....	19
Maintenance of Drum Rollers	20
Greasing Points.....	20
Maintenance of the Tightening Torques.....	21
Maintenance of the Electrical System.....	22
Replacement of the Shaft.....	23
Problems, Causes and Solutions	25
Emergency Control	26
Warranty Policy	28

1. MAINTENANCE & OPERATION HANDBOOK

- Shows the use of the machine envisaged in the project,
- Explains the technical characteristics of the truck mixer,
- Contains instructions of the relocation, adjustment, and use of the truck mixer,
- Determines the care operation of intervals and how often this care should be performed,
- Ensures the prevention of possible risks.

The manufacturer disclaims all responsibility for non-observance of the points specified in this instruction booklet for use and care.

1.1. Storage of the Guide

The “Truck Mixer Maintenance and Operation Handbook” should always be stored in the vehicle or in a suitable place for easy access.

2. SAFETY AT THE WORKPLACE

2.1. Personal Safety Equipment

ALWAYS WEAR appropriate personal protection items that must be kept in good condition and worn in accordance with the instructions.

2.2. Special Precautions

THE FOLLOWING PRECAUTIONS MUST BE STRICTLY OBSERVED DURING THE USE AND CARE!

1. The safety devices provided on the truck mixer **MUST** always **BE KEPT** in perfect working condition.
2. Temporary deactivation of one or more of the interventions and/or safety devices that need access to the maintenance area, all operations **SHOULD BE PERFORMED** only when the truck mixer is completely stationary, the engine should be turned off, and the control panel and/or vehicle keys should be on the operator.
3. For the care operations if it's necessary, the voltage source must be disconnected from the vehicle's battery and/or auxiliary engine.
4. Always check the effectiveness of the safety devices before switching on the power supply.
5. The personnel who assigned for care operations **MUST** have passed the necessary trainings and **MUST** have completely understood the "Truck Mixer Maintenance and Operation Handbook" by reading it.
6. All signposts **MUST** always be complete and readable.



WARNING: It is FORBIDDEN to lift the truck mixer, using the hooks that are present on it (these coupling points are used only at the assembly stage). For complete removal of the truck mixer, look over to the operation and maintenance guide of the vehicle in which the truck mixer is assembled).

3. PURPOSE OF USE AND IDENTIFICATION LABEL

CONCRETE MIXERS 2006/42/CE, 2006/95/CE, 2000/14/CE, 2004/108/CE are designed, manufactured and tested in full compliance with the directives and subsequent modifications and are intended exclusively for the transportation and distribution of concrete.



		Saray Mah. Bayraktar Cad. 1014. Sk. No: 3 Kahramankazan / Ankara / Türkiye	
Tip (Type)	<input type="text" value="BT"/>		
Kapasite (Capacity)	<input type="text" value="L"/>		
Seri No (Ser. No)	<input type="text"/>		
Uretim Tar. (Manuf. in)	<input type="text"/>		
		Made in Türkiye 	

Figure 1 - Identification Label

4. FEATURES

4.1. Technical Data

Model	Nominal Capacity (m ³)	Geometric Volume (m ³)	Filling Rate	Dumper Speed (dev/dk.)	Filling Capacity (min./m ³)	Unloading Capacity (min./m ³)	Water Tank (Lt.)
B3	12m ³	18,75	%64	0-14	15	15 - 40	650 Lt.
B3	10m ³	16,7	%59,8	0-14	15	15 - 40	650 Lt.
B3	9m ³	15	%60	0-14	15	15 - 40	650 Lt.
B3	8m ³	12,9	%62	0-14	15	15 - 40	650 Lt.
B3	7m ³	12,25	%57,14	0-14	15	15 - 40	650 Lt.

Table 1 - Technical Data



4.2. Dimensions and Weights

MODEL	M ³	A	B	C	D	E	Z
B3	12	7510	2820	5900	1220	11°	6850
B3	10	7955	2850	5350	1200	12,4°	6300
B3	9	6510	2750	4910	1200	12,8°	5850
B3	8	6025	2750	4410	1200	13,3°	5500

Table 2 - Dimensions and Weights

5. DESCRIPTION OF THE TRUCK MIXER



- | | |
|--|----------------------------------|
| 1. Drum | 16. Single Lever Control |
| 2. Pressurized Water Tank | 17. Control Box |
| 3. Gearbox | 18. Water Installations |
| 4. Hydraulic Motor | 19. Ladder |
| 5. Hydraulic Pump Support | 20. Distribution Chute Mechanism |
| 6. Chassis | 21. Discharge Chute |
| 7. Mudguard | 22. Folding Chute |
| 8. Hydraulic Pump | 23. Roller Mechanism |
| 9. Pneumatic System for Pressurized Water Tank | 24. V Chute |
| 10. Oil Cooler | 25. Ladder Upper Frame |
| 11. Front Support | 26. Feeding Chute |
| 12. Bicycle Bar | 27. Belt Ring |
| 13. Extension Chute | 28. Anti-Dripping Ring |
| 14. Additive Tank | 29. Metal Strip |
| 15. Rear Support | 30. Ring |

6. OPERATION OF THE TRUCK MIXER

6.1. Start-Up

Everyone involved in the use, care operations or repair of the truck mixer should receive, read, and understand the operating instructions and maintenance guide. The people who have mentioned should always help the staff who need to know the machine. It is recommended to perform the process of recognizing the machine while the truck mixer is empty. The control box is located at the back of the truck mixer with all the related levers.

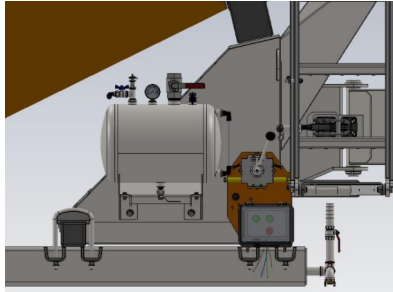

Figure 2 - Control Box

6.2. Start-Up in Winter

While working at low temperatures, the following points should be observed:

- a. Make sure that the water does not freeze inside the water pump (in the systems with water pumps). Even if the water system has been emptied from the special discharge valve, there is always a possibility of freezing.
- b. Operate the truck mixer at idle for a maximum of 5 (five) minutes, ensure that the hydraulic oil warms up.
- c. At the end of the working day or during a break from work, do the following:
 1. Open all the water system valves.
 2. Open all the water system discharge valves.
 3. Open water pump relief valve.
 4. Operate the truck mixer valve in open state, at the minimum speed for 5-10 seconds.
 5. Make sure that there is no water left in the water tank or equipment.

6.3 Filling The Water Tank

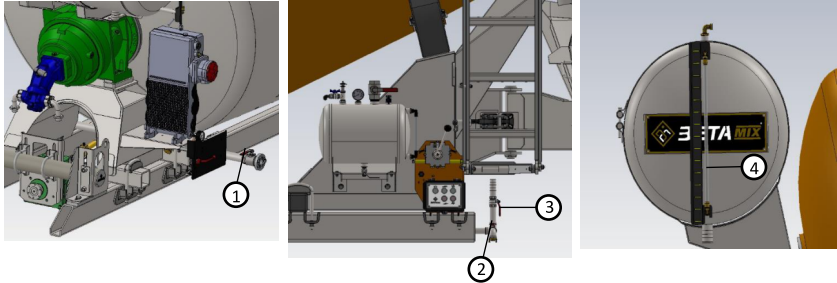

Figure 3 - Filling the Water Tank

1. Make sure that the truck mixer is turned off.
2. Make sure that the valve (1) is closed.
3. Make sure that the valve (2) is closed.
4. Make sure that relief valve (3) is closed.
5. Connect the water filling pipe with to the hose connection.
6. Open the valve (1).
7. Check the water level in the tank with the help of the level indicator (4) on the tank. When the water flows through the drain pipe in the tank, the tank is completely filled.
8. Disconnect the water filling pipe from the hose connection.

6.4. Filing The Drum

1. Fill the water tank as shown on page 9.
2. Place the truck mixer so that the exit will come under of the concrete batching plant.
3. Move the mechanical control to the filling direction, start the vehicle at a speed of at least 1500 Rpm. (If the filling capacity of the power plant is too high, take the speed of the vehicle to 1700 Rpm).



WARNING:

Never load the truck mixer more than its capacity!

After the filling process is completed, please pay attention to the following notes before shipping:

- Make sure that the lock placed in the discharge chute for this purpose is closed.
- If there is one, make sure that the folding chute is folded back and make sure that it is fixed thanks to the fixing part used for this purpose.
- Make sure that the ladder is folded and locked thanks to the hook placed for locking purposes.
- Make sure that the extension chutes are fixed to the support.

7. LOADING OPERATION

7.1. Loading Location

After filling the water tank and checking that the machine is operating under proper operating conditions, position the truck mixer by aligning the loading chute under the main discharge channel of the mixer. Adjust the speed and direction as necessary during the loading.

The rotation speed should be proportional to the unloading capacity of the distribution line (generally 15 revolutions/minute).



WARNING! Depending on the specific gravity of the material being shipped, never load the truck mixer more than the maximum rated capacity specified.

7.2. Post-Loading Inspection Before Shipment

After the loading process, pay maximum attention to the following points before shipment:

- Please check that the distribution chute is closed with a reverse closing device.
- Check that the folding chute (if available) is closed and connected to the distribution chute with the appropriate connecting rods.
- Check that the lower part of the ladder is folded and that it is locked with the connection hook.
- Check that the extension chute is positioned correctly and locked to the connection supports.

7.3. Preparations for Shipment and Unloading

During shipments, adjust the drum speed to 1.5-2 revolutions/minute. Avoid sudden acceleration and brakes.

7.4. Mixing

If the norms of the country where the user is located allows, increase the rotation speed when the upload is completed and keep the speed constant until the mixing of the content is completed (The time required for the completion of this stage depends on the type of material being mixed).

For the various materials that will be mixed, it is recommended to perform some trial operations to create specific tables.

8. CLEANING GUIDE OF THE TRUCK MIXER

Before a long work break or at the end of a working day, it is always necessary to clean the parts of the truck mixer that are in contact with concrete. If it is necessary, spraying water can be used.

- Even if the bearings are protected against splashing water, avoid spraying water directly on them.
- The discharge chute, the feeding chute, the additional chutes, the folding chute and all the parts in contact with the concrete, must be cleaned.
- Fill the truck mixer drum with 150/200 Lt of water and leave it rotating during the return trip to the resort; then empty it and repeat the process if necessary.
- To facilitate the further cleaning, after the parts have been thoroughly cleaned, they should be covered with a thin layer of oil.
- Always make sure that the bearings and pistons are free of cement.



WARNING: Do not use corrosive and acid-based chemicals during the truck mixer cleaning. Corrosive and acid-based chemicals can damage the working parts of the truck mixers and painted surfaces.

- The truck mixer should not be cleaned with steam spray for the first 8 weeks.
- The entire truck mixer can be cleaned with water and suitable cleaning materials.
- No responsibility is accepted for the damage caused to the machines when the rules are not followed and harmful additives are used.

High pressure water retention should be avoided on the panel, hydraulic jack and the covers at the shaft entrance of the hydraulic pump.



WARNING: Plastic parts must be cleaned with oil!



WARNING: Make sure that there is no waste concrete left in the truck mixer at the end of each working day and clean them if there is any!

9. MAINTENANCE OF THE TRUCKMIXER

Repair and maintenance operations should be performed by authorized personnel who have received training in working with this type of machine. During these operations, the specified safety norms and precautionary measures must be complied with compulsorily.

- All parts that have contact with concrete must be cleaned after the unloading process.
- The hydraulic oil and filter should be changed once a year in any case, even if the mixer has not reached the specified operating time.
- Maintenance operations should be carried out at regular intervals and care operations on other parts of the machine can be easily planned to suit their work.
- Since a convenient care operations schedule will depend on the specific operating conditions and practical application, the care operation intervals in the table are only a guideline.

CONTROL TYPE	DAILY (8hours/1)	WEEKLY (40hours/1)	FIRST EXAMINATION (200hours/1)	EVERY 6 MONTHS (1000hours/1)	EVERY YEAR (2000hours/1)
Checking the Oil Level of the Gearbox	✓		✓		
Hydraulic Oil and Filter Replacement			✓		✓
Cleaning the Wings of the Oil Cooler			✓	✓	
Greasing the Ring of the Drum	✓		✓		
Greasing the PTO Shaft		✓	✓		
Checking the Tightening of the PTO Flange		✓	✓		
Checking and Greasing the Cable of Control Box			✓	✓	
Greasing All the Greasing Point		✓	✓		
Checking the Possible Hydraulic Leak		✓	✓		
Checking the Fan of the Oil Cooler		✓	✓		

Table 3 - Periodic Care Guide Table

CONTROL TYPE	PERIOD	TYPE	STANDARD
Checking the Oil Filter	200 hour		
Checking the Motor Oil Level	8 hour		
Checking the Joint Bolts	200 hour		
Checking the Gearbox Oil Level	8 hour	85W/140-90 Gear Oil	APL GL 5 MIL L2105 D
Replacement of the Hydraulic Oil and Filter	2000 hour	Tellus 52 M 68	MIL L2105 C
Greasing the Drum Ring	8 hour	Graphitic Grease	
Greasing the Shaft and Checking of the Bolt	40 hour		DIN51520K2K NILG12
Greasing the Single Lever	200 hour	Graphitic Grease	
Checking and Filling of the Grease Nipples	40 hour		DIN51520K2K NILG12

Table 4 - Types and Periods of Control

9.1. Corrosion and Replacement of Metal Parts

Check the wear of the mixer spiral protection plate and internal spirals, chutes, feeding and discharging chutes. If one or more of them is damaged or worn, they should be replaced.



WARNING: If the spiral protection plate is worn, be sure to replace it. The service life of the intra-drum spirals depends entirely on the good condition of the protection plate. Be sure to contact the Betamix After-Sales Services Department for the replacement of the drum.



ATTENTION! Without a mechanical lock, the drum can rotate, so it is **FORBIDDEN** to operate on the truck mixer without first installing a mechanical lock system!

9.2. Maintenance of the Hydraulic System

Thanks to the indicator installed on the oil tank, check the oil level in the oil cooler daily. If the level is below the minimum level, immediately investigate the cause, repair the leaks and complete the oil level with the same brand of oil.

Replace the hydraulic oil with the oil specified in Table 4 with the recommended intervals. At each oil change, the oil filter must also be replaced.

When the filter is tried to be cleaned, it will cause the filter to rupture. Change the filter more often when it is heavily polluted.

9.3. Replacement of the Oil of the Hydraulic System



WARNING: DANGER OF BURNS! In some cases, the oil tank and the oil can reach high temperatures; take care during operation and always use adequate individual protective equipment!

Follow the steps below for changing the oil:

- Turn the truck mixer to the horizontal position.
- Stop the truck mixer and turn off the vehicle's engine and auxiliary engine.
- Place a storage with a capacity of about 35 liters under the oil cooler.

- First, open the filling, then the drain plug.
- Wait until all the oil is drained.
- Place a 10 Lt. container under the hydraulic pump.
- Remove the leak hose record on the hydraulic pump.
- Wait until the oil flow stops, grip the record into place.
- Tighten the oil cooler drain plug.
- Unscrew the cartridge cover from the filter housing and pull it out together with the filter cartridge.
- Remove the nut at the end of the filter support rod and replace the filter with a new one.
- Fill the oil until it appears on the oil cooler level indicator.

9.3.1. Replacement of the Oil Filter Cartridge

The fact that the vacuum meter located next to the cartridge shows a **RED** color indicates that the filter is dirty and definitely needs to be replaced.



WARNING: If the filter is dirty or clogged (if the vacuum meter indicator is RED), cavitation may occur in the auxiliary pump due to abnormal operation of the machine and the risk of damage to hydraulic devices.

IT IS FORBIDDEN TO START THE MACHINE IF THE VACUUM METER INDICATOR IS RED!

Perform the filter cartridge replacement process as follows:

- Unscrew the red cover on the filter bracket and remove the filter cartridge (at the same time close the inner valve to prevent the oil inside the oil cooler from flowing out).
- Remove the nut attached to one side of the filter fixing rod connector and replace the cartridge with a new one.
- Close the filter by checking that it fits properly; replace the round seal if necessary.
- Fill the oil cooler tank with oil of the same type and with the same characteristics in the oil table.
- Start the truck mixer at the minimum level, let the drum rotate at a very slow speed and refill the oil.

- Check the tightness of the covers, change the gasket if necessary.
- Check that there are no leaks at the joints.

9.4. Maintenance of the Gearbox

In the event that the truck mixer is started for the first time, make sure that the oil level in the gearbox is above its minimum level.

9.4.1. Replacement of the Gearbox Oil



Figure 4 - Gearbox



Figure 5 - Gearbox

1. Feeding Plug
2. Level Indicator
3. Discharge Plug

For easier draining of oil, make the oil change while the oil is hot.

For changing the oil, act as follows:

- 1) Park the truck mixer in a flat/slope-free area.
- 2) Stop the truck mixer and turn off the diesel engine.
- 3) Place a waste oil container with a capacity of about 35 liters under the gearbox.
- 4) Remove the drain plug (3).
- 5) Wait until all the oil is drained.
- 6) Screw the drain plug onto the gearbox.
- 7) Fill the gearbox to the minimum level (2).
- 8) Start the truck mixer again and continue idling in a holding pattern.
Turn the truck mixer at a very slow speed (2 turns per minute) and make sure that the oil does not fall below the minimum level mark on the indicator or below the mark (1) on the dipstick.
- 9) Make sure that the plugs are tight and if necessary, replace the seals.

9.5. Maintenance of the Water Pump

As a safety precaution against overloads; if the water pump is connected directly to the gearbox, the connection should be made with a coupling made of special plastic material. If the pump is locked, the plastic coupling prevents more serious damages from occurring.

The plastic coupling should be replaced as follows:

- 1) Unscrew the gearbox from the fixing screws.
- 2) Turn the water pump shaft by hand (the shaft should rotate freely without fitting).
- 3) Remove the damaged or broken coupling.
- 4) Put a new plastic coupling.
- 5) Place the pump by making sure that all parts are adjusted.
- 6) Tighten the gearbox with fixing screws.



WARNING: Do not operate the water pump without water at all, even for testing purposes!

9.6. Maintenance of the Drum Rollers

- 1) Make sure that all drum rollers rotate freely and are placed correctly.
- 2) If the rollers will get stuck, the truck mixer couldn't be repaired, to avoid damage replace it immediately.
- 3) Lubricate the drum rollers regularly using a grease pump.

9.6.1. Greasing Points

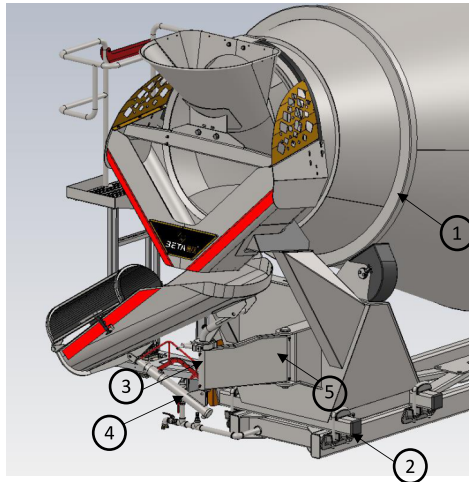

Figure 6 - Grease Points

NO.	DESCRIPTION	GREASING POINTS
1	Drum Ring	1
2	Carrier Roller Pin	2
3	Mechanism Hub Pin	2
4	Groove Lifting Piston	1
5	Mechanism Retainer Pin	2
6	Mechanical Control Box	1

Table 5 - Grease Points

9.7. Maintenance of the Tightening Torques

All screws and clamps of the truck mixers should be checked according to the maintenance guide and if necessary, it should be tightened.

Check Every

- Inspection after the first 200 working hours,
- Inspection after 1000 working hours,
- Every 1000 hours, the bolt connections (Figure 7) are checked and tightened to the values shown in Table 6.

AREA	COMPRESSION TORQUE (Nm)
A	350
B	400
D	260

Table 6 - Torque Values

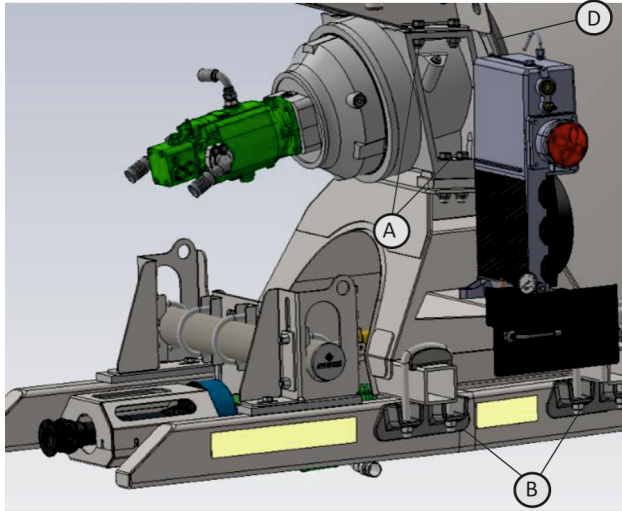

Figure 7 - Squeeze Points

9.8. Maintenance of the Electrical System

The care options of the electrical panel should be carried out by trained personnel. The electrical system is made in accordance with European standards. The degree of protection of both the electrical panel and the entire system is IP64. The voltage of the panel is 24- or 12-Volts DC. This voltage is also given directly to the panel. The electrical panel is placed for transmission control and there is a protection box against external factors. Nevertheless, it should be protected against external factors as much as possible.

Damages arising from improper use of the electrical panel or from such improper use is **outside the warranty scope**.

- 1) Turn off the main switch (cut off the electrical current, do not operate on the electrical panel without turning it off).
- 2) Please check the relevant fields.



WARNING:

- 1) Never do the work when the electrical panel turned on!
- 2) In case of fire, never extinguish it with water!
- 3) The transparent cover on the illuminated control panel should always be kept closed!
- 4) Before doing welding work, disconnect the electrical panel from the welding power line and be sure that the truck's batteries are disconnected!

9.9. Replacement of the Shaft

In the truck mixers driven by truck PTO, the hydraulic pump is connected to the PTO by a drive shaft.

The drive shaft should be placed as follows:

- 1) Clean the surface that meets the flange from all paint, dirt, grease, protective coatings and other materials (3).
- 2) Eliminate all kinds of defects.
- 3) Do not apply oil or grease on the surfaces that correspond to the flange.
- 4) Make sure that the opposite flange on the vehicle or equipment does not have any ovalization, distortion or balance when rotating (3-2).
- 5) Put the drive shaft in place (1), do not hammer the flanges or use a similar force such as a crowbar on the crosses.
- 6) Make sure the position of the crosses and the reference arrows are aligned correctly.
- 7) Do not modify the holes and thickness of the flanges for any reason.
- 8) Grease the grease points on the drive shaft after assembly.
- 9) Operate the truck PTO and make sure that there is no balance when the shaft rotates.
- 10) Make sure that the shaft position angle is Zero (0°) degrees.
- 11) Make sure that the shaft position angle, in necessary cases, does not exceed three (3°) degrees.
- 12) Make sure again that all the bolts are tightened.

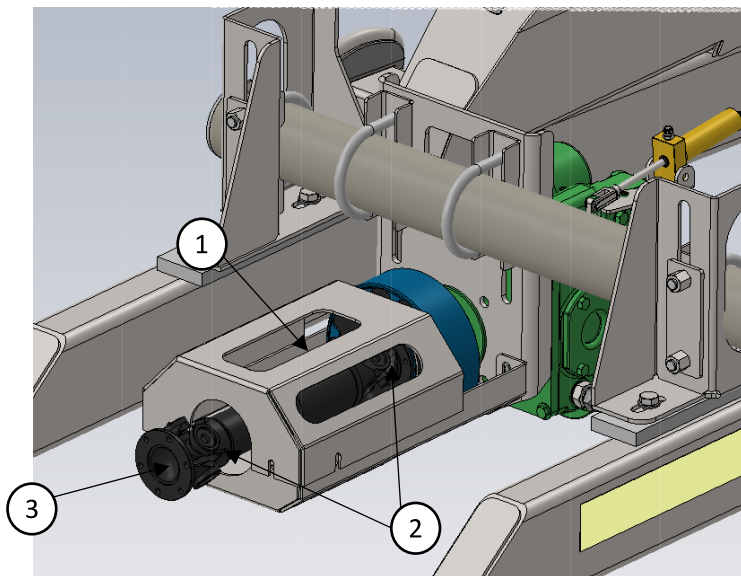

Figure 8 - Replacement of Drive Shaft

10. PROBLEMS, CAUSES AND SOLUTIONS

PROBLEM	POSSIBLE CAUSE	SOLUTION
The drum does not rotate or rotates too slowly with hot oil.	The power supply pump of the hydraulic pump has failed.	Check the pressure in the supply circuit; if it is below 12 bar, replace the feed pump.
The drum does not rotate or rotates too slowly with hot oil (the high pressure gauge shows the optimal values applicable to the specific type of current load).	The hydraulic motor has failed.	Replace the hydraulic motor. If there is any material in the drum, load some water and oil immediately to delay the solidification of the material inside. Go to a suitable center for material/waste casting and insert the mechanical block device into the drum, open the inspection hole and discharge as much material as possible. Also wash and clean all internal and external parts. First disconnect the tubes connected to the hydraulic motor, then disconnect the motor from the gearbox.
	The maximum pressure valves of the hydraulic motor are clogged.	In this case, a sound similar to a whistle can be heard, and this sound means that the oil in the high pressure circuit is draining. Remove and/or replace the relevant valves.
The "zero" or "neutral" position of the drum does not coincide with the corresponding position of the control levers.	The fixing screws of the control cable of the hydraulic pump have come loose.	Loosen the hydraulic pump, the two adjustment nuts of the cable of the hydraulic pump on the widening iron located on the pump; the service control lever of the hydraulic pump automatically turns to the neutral position. Readjust the corresponding screws on the control box by tightening them and retighten the adjustment nuts that were loosened earlier.
When one of the control levers is used, there is no immediate reaction to the selected related function.	The filter inside the oil cooler is very dirty and clogged.	Replace the filter with another filter with the same properties.
The temperature of the hydraulic oil is very high (about 80 °C/85 °C).	The oil level in the oil cooler is below the minimum amount.	Replace the hydraulic motor. If there is any material in the drum, immediately add some water and oil to delay the solidification of the material inside. Go to a suitable center for material/waste casting and insert the mechanical block device into the drum, open the inspection hole and discharge as much material as possible. Also wash and clean all internal and external parts. First, disconnect the tubes connected to the hydraulic motor then disconnect the motor from the gearbox.
	The fan of the oil cooler is not working.	Make sure that the connection plug between the cooling fan and the electrical cables is inserted into the appropriate connectors.
		Replace the wobbled thermometer.
		Replace the control relay of the cooling fan.
		Replace the cooling fan.

Table 7 - Problems, Causes and Solutions

11. EMERGENCY CONTROL

In case of failure of the auxiliary engine and/or its hydraulic pump, an emergency system must be prepared and connected to another truck mixer under operating conditions. The figure below shows how the emergency system should be.



WARNING! The system should be used only for unloading the drum and preventing solidification of the material inside.

The system consists of a series of hydraulic hoses of sufficient length and equipped with suitable fittings to allow connection to another truck mixer.

Before starting to use the emergency system, check whether there is another reason behind the malfunction.

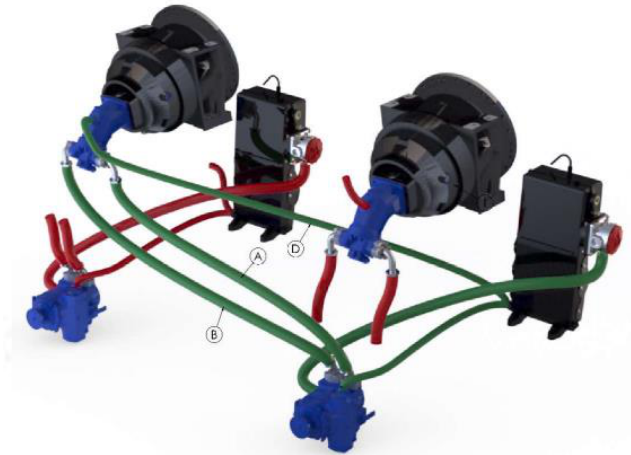

Figure 9 - Emergency Hose Connections

Red Hose: The idle one

Green Hose: Where the flow is

Connect the hoses as described above (Figure 9).

- 1) Fill all hydraulic hoses with the oil according to the specifications in Table 4.
- 2) Complete the oil levels as required.
- 3) Check the O-ring in the flanged connection and replace it if necessary.
- 4) Making sure that they are placed correctly (Figure 9), screw the corresponding records and connect them to the high-pressure hydraulic hoses A and B and the hydraulic line D.
- 5) Please be very careful not to miss foreign objects in the hydraulic system.
- 6) Please check again that the hydraulic pump records are tightened.
- 7) Activate the emergency system and make sure that there is no oil leakage.
- 8) Drain all the ingredients from the drum.
- 9) Wash the drum thoroughly.
- 10) Please contact to our dealers and authorized services to repair the malfunction.

12. WARRANTY POLICY

Concrete mixers that we have produced as Betamix;

- Using as shown in the 'Truck Mixer Maintenance and Operation Handbook',
- Making the maintenance and repair by the technical service personnel we have authorized,
- Performing daily, weekly and monthly care in accordance with the maintenance lists we have shared with you in case of these, including all its parts, we commit that it is fully covered by the warranty for a period of 2 (two) years against workmanship and manufacturing defects.
- The determination of the technical methods to be applied for the elimination of malfunctions and the detection of the parts to be changed belongs entirely to our company.
- The warranty period of the material replaced during the warranty application is included in the remaining warranty period of the purchased concrete mixer.

In Our Concrete Mixers;

- Malfunctions caused by using it contrary to the considerations contained in the handbook,
- Malfunctions that occur during loading, unloading and shipment after delivery of the concrete mixer,
- Malfunctions that may occur as a result of care operations and repair that do not comply with the conditions specified in the handbook of the concrete mixer,
- Malfunctions that will occur as a result of care operations and repair work by unauthorized personnel **are not included in the warranty coverage.**

We are always with you, together with our authorized services and branches for the elimination of malfunctions in the concrete mixer.



BETA MIX[®]

BETA İŐ MAKİNALARI SAN. VE TİC. LTD. ŐTİ.

Malıköy Mah. BaŐkent OSB. 56. Sk. No: 1/1, Sincan / Ankara

T: (0850) 223 23 82

www.beta-mix.com.tr